



SANWA

SE-200

DIGITAL REVOLUTION COUNTER
CONTACT TYPE

SANWA

SANWA ELECTRIC
INSTRUMENT CO., LTD.
Dempa Bldg, Sotokanda 2-Chome
Chiyoda-Ku, Tokyo, Japan

INSTRUCTION MANUAL

SE-200

DIGITAL REVOLUTION COUNTER
CONTACT TYPE

The unit is designed with a concept to pursue the best availability of human engineering. It is a high-precision, wide measuring, contact-type digital revolution counter.

Main Features

- The unit is designed to pursue operational efficiency and easiness of hand touching as a handy type measuring instrument. It is, yet, solid and robust.
- A wide range of 60-20000 rpm can be measured. And the accuracy is exceedingly high.
- rps (revolutions per second) can also be measured.
- Incorporating DATA HOLD function.
- Incorporating AUTO POWER OFF function.

Ratings

Measuring mode

: rpm (revolutions per minute)/rps (revolutions per second) switching system

Measuring range

| Range | rpm | rps (one range) |
|-------|------------|-----------------|
| X1 | 60 ~ 9999 | 1 ~ 333 |
| X10 | 60 ~ 20000 | 1 ~ 333 |

Measuring time

: For one sec. Measurement is repeated automatically

Display

: Max. reading 9999 in LED

Overranging indication

: Overranging indication LED lights at over 9999.

Accuracy

: ± 1 digit in X1 range (Electric operation)
 ± 2 digit in X10 range (Electric operation)

With revolution confirming indication

With low battery alarming function

With AUTO POWER OFF function

Used power source : Four SUM-3 (R6) batteries

Using hours about 17 hours

(Continuous use)

about 68 hours (Normal use)

Using temperature range : $0^{\circ}\text{C} \sim +40^{\circ}\text{C}$

Size • weight : 183 x 42 x 31mm, approx. 210 g

Accessories : 1. Instruction manual 1 copy

2. Contact adapter 1 pce

3. Contact rubber 3 pcs

4. Hexagonal wrench 1 pce

5. Cycling speed ring (SE-10) 10 mm thick (Option)

6. Cycling speed ring (SE-1.5) 1.5 mm thick (Option)

7. Carrying case (Option) 1 pce

The Name of Each Part

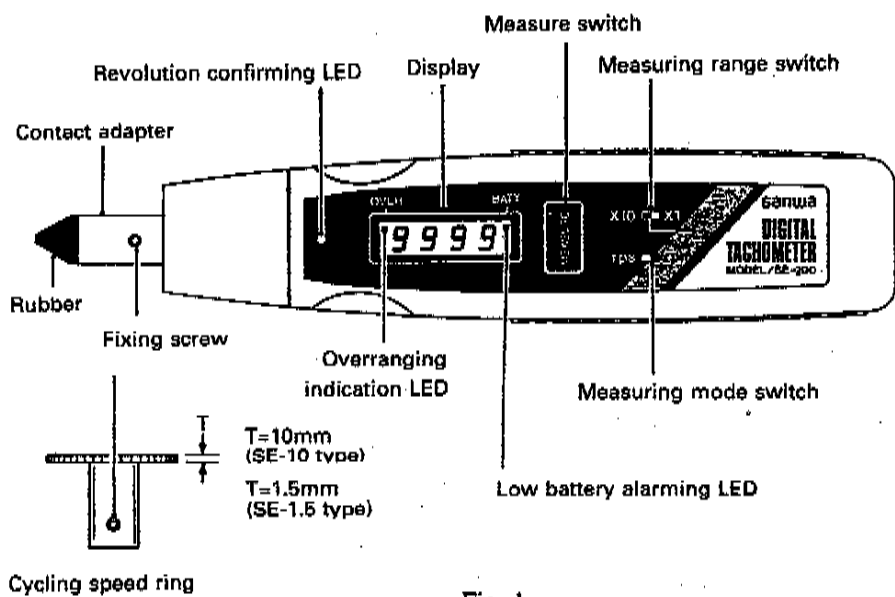

Fig. 1

General Precautions

1. Before using the unit, be sure to confirm whether the inner batteries are good enough to drive the unit perfectly. Refer to page 7 for the batteries.
2. Enough care should be taken to handle the unit as measurement is done by letting the unit directly touch revolving target.
3. Do not use the unit for over one continuous minute for the measurement of a high-speed revolving target (Over 8000 rpm). For, heat generation of the inner bearings by a high-speed revolution may be considered.
4. Do not do the measurement of over 20000 rpm as heat may be generated in the bearings or the life of the bearings may be shortened, although it is possible for the unit to do so.
5. Overranging indication of the unit is made if measured value is over 9999. For example, if revolving target of 10000 rpm is measured in rpm mode and in X1 range, the display shows 0000 rpm and the overranging indication LED flickers, showing that measured value is overranging.
6. Do not leave the counter for a long time in a place where much shock or vibration is given, under the direct rays of the sun, or in a high or low temperature or in a high humidity. If the counter is not used for a long time, it is advisable to take out the batteries from the counter.

How to Use the Counter

Read carefully each item of "General precautions" before using the counter.

1. Measuring rpm (revolutions per minute)

- 1-1 Set the measuring mode switch to rpm side.
- 1-2 Set the measuring range switch to a desirable range.
- 1-3 Apply the tip (contact rubber) of the unit to the center of the axis of revolving target at a right angle against the contact surface as shown in Fig. 2 and depress the measure switch, and measured value is shown. To obtain actual measured value, multiply indicated value with the multiplication factor of the measuring range switch.

Example:

If indicated value is 2000, read it out directly in X1 range or read it out after multiplying it by 10 in X10 range. Measured value should be 20000 rpm in the latter case.

- 1-4 When the measure switch is released from the depressing finger, measured value then is kept held by DATA HOLD function. And the counter is powered off automatically in about 10 sec.
- 1-5 When the measure switch is depressed again, measurement can be done again. Take care, however, the previously-measured value is cleared out then.

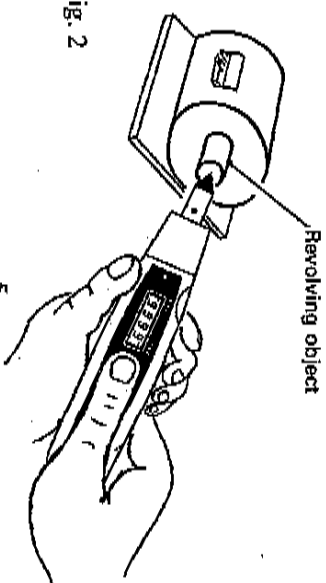

Fig. 2

2. Measuring rps (revolutions per second)

Set the measuring mode switch to rps side and do the same operations and measurements as shown in the foregoing "Measuring rpm". In this case, however, there is nothing to do with the measuring range switch, so indicated value can be read directly as measured value.

For example, if indicated value is 0333, measured value is 333 rps.

3. Measuring Cycling Speed

When cycling speed such as the speed of endless belt is measured, loosen the fixing screw of the contact adapter, exchange the adapter with optional cycling speed ring, and attach the ring to the unit firmly with the fixing screw.

3-1 Set the measuring mode switch to rpm side.

3-2 Set the measuring range switch to a desirable range.

3-3 Cycling speed value is shown in the display when the cycling speed ring is applied in parallel to measured target as shown in Fig. 3 and the measure switch is depressed. Indicated value should be multiplied by 1/10 when the measuring range switch is set to X1 range. Indicated value should be read out directly when the measuring range switch is set to X10 range. These indicated values should be read out in the unit of m/min.

Example:

If indicated value is 2000, measured value is 200 m/min. in X1 range and measured value is 2000 m/min. in X10 range.

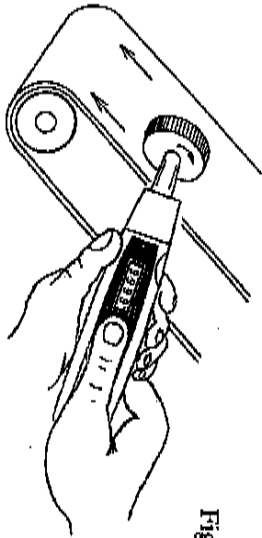

Fig. 3

Battery

1. Battery Attachment

1-1 Detach the battery cover on the rear side of the unit by strongly depressing its stopper and pulling it towards you as shown in Fig. 4.

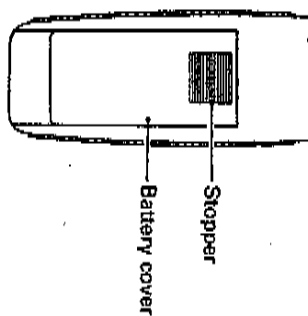

Fig. 4

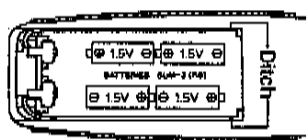

Fig. 5

1-2 Place four SUM-3 (R6) batteries into the battery compartment with the direction of their polarities correctly arranged as shown in Fig. 5. In this case, battery attachment can be done easily if the innermost two batteries are attached first.

1-3 Place the battery cover on the ditch as shown in Fig. 5. Undo the battery cover by pushing it up in a sliding mode.

2. Battery Replacement

The inner batteries have worn out in such a condition as they do not satisfy the ratings of the unit if the low battery alarming LED in the display lights as in Fig. 5 with the measure switch kept depressed. Replace them with new ones at once. Also, do battery replacement if nothing is shown in the display. Battery replacement should be done in a similar way as in "1. Battery Attachment".

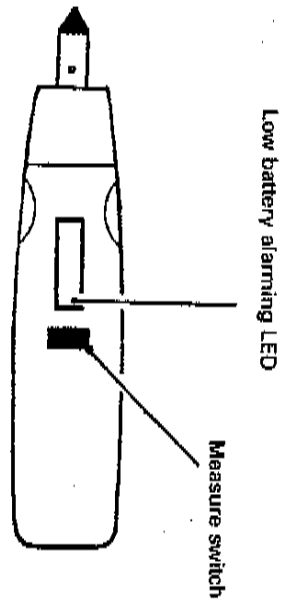

Fig. 6

Specifications herein may be changed for improvement without notice.