

sanwa

VS-100
INDUSTRIAL TESTER

OPERATOR'S MANUAL

NAMES OF PARTS

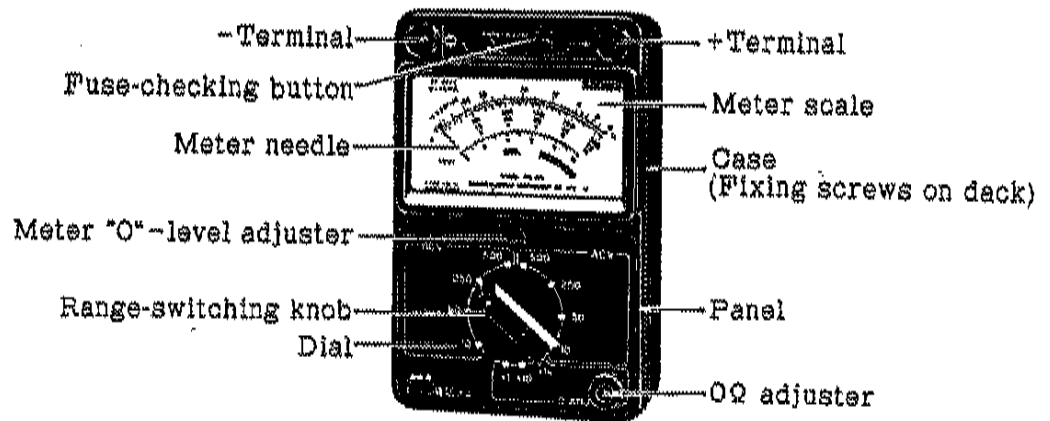

FOREWORD

An ordinary tester is a convenient instrument for measuring voltage, current and resistance. But incorrect use or maintenance can sometimes be very dangerous to the user and destructive to the tester itself. The VS-100 model is a safe tester for large-current, low-voltage circuits and is manufactured with first priority given to safety.

Besides the elimination of a current range that would rarely be used and that poses great danger when wrongly measured, the VS-100 contains a small-current cut-off fuse (glass tube) with an upper limit of 250V plus a cartridge current-limiting fuse (porcelain tube) with a large cut-off capacity of up to 600V (AC/DC maximum for internal shorting). Fire-resistant registers are also employed. These design features make the tester and its test leads highly safe.

But no such instrument can be perfectly safe. Please remember that what you are measuring is a strong electric current when you are using this tester. Maintain it in proper condition. We also recommend regular inspection. With these precautions, the VS-100 will serve you safely and well.

Please read this instruction manual carefully so as to obtain the best possible measurements and to ensure your safety while doing so.

FOR SAFE, CORRECT USE

- ① The VS-100 is a tester for large-current, low-voltage circuits. It must be used only for circuits of voltage less than 500V.
- ② Check the built-in fuses before making measurements.
- ③ Each time you use the tester, confirm the position of the range-switching knob.
- ④ The built-in fuses are a small-current cut-off fuse (glass tube) and a large-current cut-off fuse (porcelain tube). If your checking of the fuses prior to making a measurement indicates that there is a problem, both fuses must be checked with another tester or other testing equipment to determine which fuse is broken. (In some cases, both fuses may be broken.)
- ⑤ Replacement fuses must be those specified (see Specifications, page 9 in this manual). The use of fuses other than those specified is very dangerous and also will cause errors in the measurements.
- ⑥ The use of defective fuses is extremely dangerous. Never use such a fuse.
- ⑦ Do not use a test lead having a damaged insulating cover or joint in the middle, or a lead with a broken lead probd. All of these conditions are dangerous.
- ⑧ Built-in batteries, when worn, should be replaced

by new ones of the same kind. If a worn battery is left inside the tester, the electrolytic liquid sometimes leaks out and corrodes the tester's internal parts.

- ⑨ Carry out regular inspections regarding such points as ratings and withstanding voltage, at six-month or one-year intervals.

MEASUREMENT INSTRUCTIONS

1. Beforehand Operation

① Meter "0" Position Adjustment

Turn the meter "0"-position adjuster to set the needle at the "0" position on the left side of the scale.

② Range Switching

Turn the range-switching knob to change the measurement range. There is a total of 11 ranges, for resistance (Ω), alternating current (ACV) and direct current (DCV).

③ Connecting Measurement Terminals to Test Leads

Insert the red test lead to the (+) terminal and the black test lead to the (-) terminal. Insert the

leads deeply, reaching the bottom of each plug, and plug covers fully over the projecting parts. The plug covers prevent unexpected disconnection of test leads due to the tester's weight.

④ Checking the Fuses

Checking the fuses before and after a measurement confirms the presence or absence of electricity. To do so, short the two leads by pressing them together and then press the FUSE CHK button. The needle will stay within the blue portion of the FUSE GOOD range if the fuses are normal. This also indicates that the meter and the other circuits are in normal condition. Fuse-checking can be done at any measurement range setting.

If the built-in batteries are worn and even "0" Ω adjustment is impossible, the needle will not move to the FUSE GOOD range ① in the case of a V range or to the FUSE GOOD range ② in the case of a Ω range.

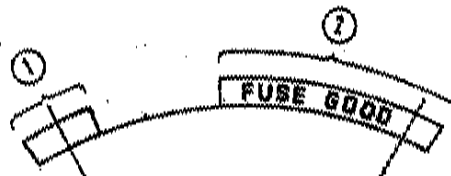

⚠ If the built-in batteries and fuses are normal but the needle moves out of the normal range during fuse-checking, there is a problem elsewhere in the tester.

2. Measurement of DCV and ACV

① To measure DC, note the polarities carefully and measure voltage by connecting the leads in parallel with the circuit.

② When measuring is incorrectly done, the following will happen.

If the AC range is added to the DC range, the needle will not move.

If the DC range is added to the AC range, the needle will indicate "0" or a double rating depending on the polarity.

3. Measurement of Resistance (Ω)

① Short the test leads (red and black) to move the needle, then turn the "0" adjuster to set the needle at "0" position. This avoids wear of the built-in batteries and also prevents Measurement error due to loading current.

② Next, connect the leads to the circuit. The measured value is obtained by multiplying the value on the blue scale by the multiplier to which the range-switching knob is set.

* If the needle does not move to "0" Ω when the "0" Ω adjuster is turned fully to the right, or in the $\times 1$ range the "0" adjustment is set but soon changes, it means that the built-in batteries are worn. Remove the case cover and replace the batteries with new ones (R6 or UM-3).

* Due to the built-in batteries, the range shows reverse polarity display of terminals (+) and (-).

4. Important Points for Handling and Storage

- ① It is best to place the tester in a horizontal position so as to view the needle from directly above. This helps prevent misreadings.
- ② Placing the tester in a strong magnetic field or on machine tools or iron and steel plates will cause measurement errors. Also, measuring while the tester is resting on a machine tool or metal plate is very dangerous. Do not place the tester in such locations.
- ③ When selecting the measurement range for voltage measurement, choose a range that can be read with the right-hand scale. For resistance measurement, choosing a range that can be read with the center scale gives high readout precision with less measurement error.
- ④ Since the tester is a very delicate instrument, protect it from vibration and shock.
- ⑤ Avoid exposure of the tester to direct sunlight or storage in high-temperature and high-humidity locations.
- ⑥ For long-term storage, the built-in batteries should be removed.

EFFECTS OF OVERLOADING

If an overload below 500V is applied to the VS-100 model, in any measurement range, the built-in fuses and some of the oxidized metal-coated resistors will be damaged. There will be no damage such as electric discharge or burning of resistors, however. This means that there will be no harm to the interior of the tester or to the user by flame or smoke.

The chart below shows overloading test data for each range. (Weld time of five seconds)

(See the next page)

Overload test table

Impressed Voltage (50Hz)	AC 100V	AC 200V	AC 500V	AC 1kV	Resistor
	20kVA	20kVA	15kVA	13kVA	
DC 10V	○	○	○	○	
" 50V	○	○	○	○	
" 250V	○	○	○	○	
" 500V	○	○	○	○	
AC 10V	○	○	○	○	
" 50V	○	○	○	○	
" 250V	○	○	○	○	
" 500V	○	○	○	○	
Ω ×1	☐	☐	☐ ● ●	☐ ● ●	R8
" ×10	☐	☐	☐	☐ ● ●	R7
" ×1k	○	○	○	●	R5, R6
内部短絡	☐ ●	☐ ●	☐ ●	☐ ●	

○:normal ●:resistor breaks ☐:0.25A fuse melts ●:5A fuse melts

SPECIFICATIONS

[Measurement Range]

DCV : 10 50 250 500 (4k Ω /V)

ACV : 10 50 250 500 (4k Ω /V)

Resistor (Ω) : $\times 1$ $\times 10$ $\times 1k$
 0~2k Ω 0~20k Ω 0~2M Ω

[Allowance]

DCV, ACV : Within $\pm 3\%$ of maximum scale rate

Ω : Within $\pm 3\%$ of scale length (of arc)

[Built-in Batteries]

Dry battery R6 (SUM-3) $\times 2$

[Built-in Fuses]

Catridge current-limiting fuse $\times 1$	Glass-tube fuse $\times 1$
Type FUJI-BLA003	($\phi 6.4 \times 30$ mm)
Rated voltage 600V	250V
Rated current 3A	0.25A
Cut-off current capacity 100kA	100A

[Test Leads]

TL-100 type

[Withstanding Voltage]

When AC 2.5kV is applied for one minute between the electric circuit and the outer case, there should be no abnormal effects.

[Outer Dimensions/Weight]

144 × 96 × 56 (mm) - 395 g

CIRCUIT DIAGRAM (A)

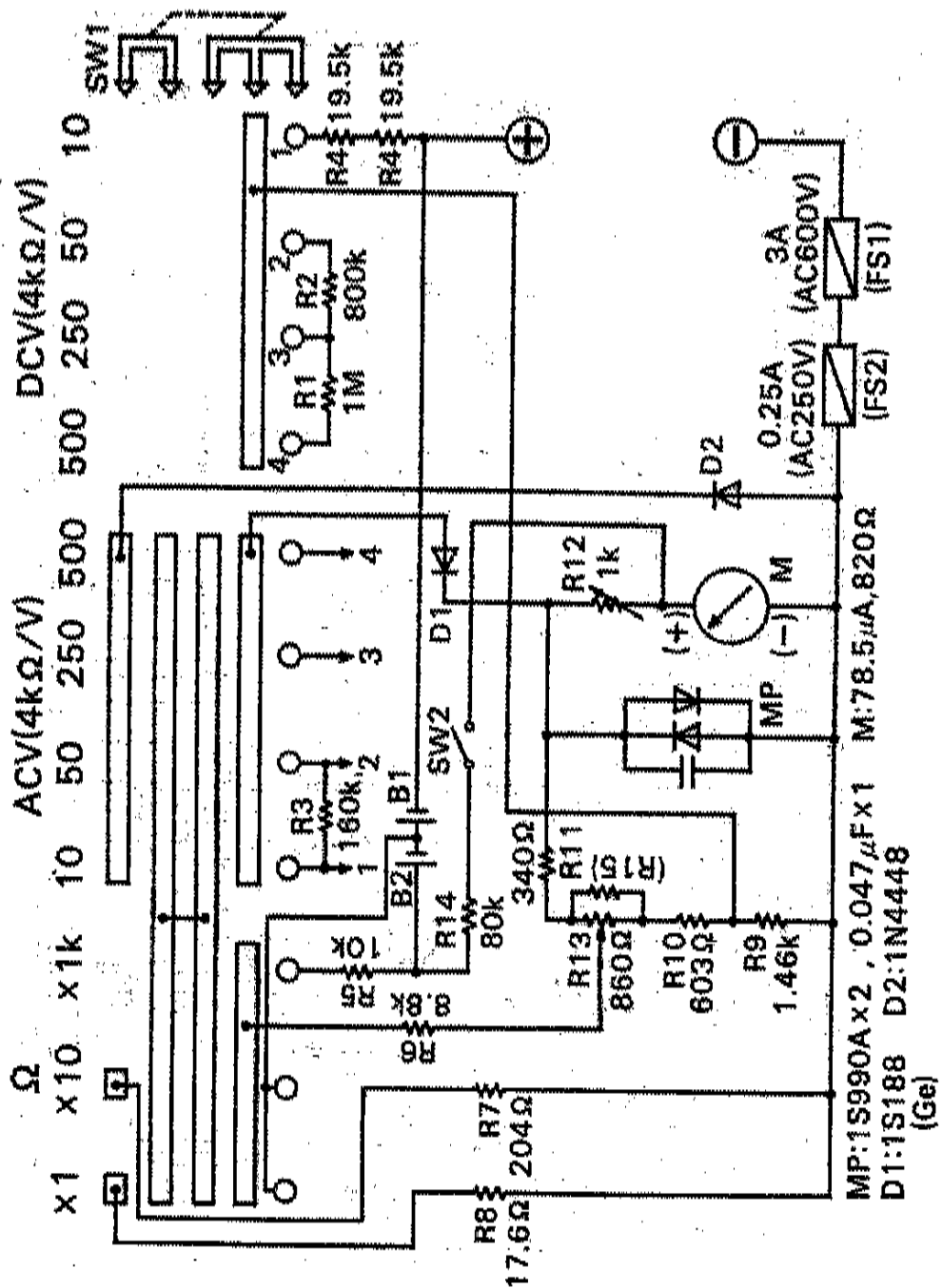

PARTS LOCATION (rear view)

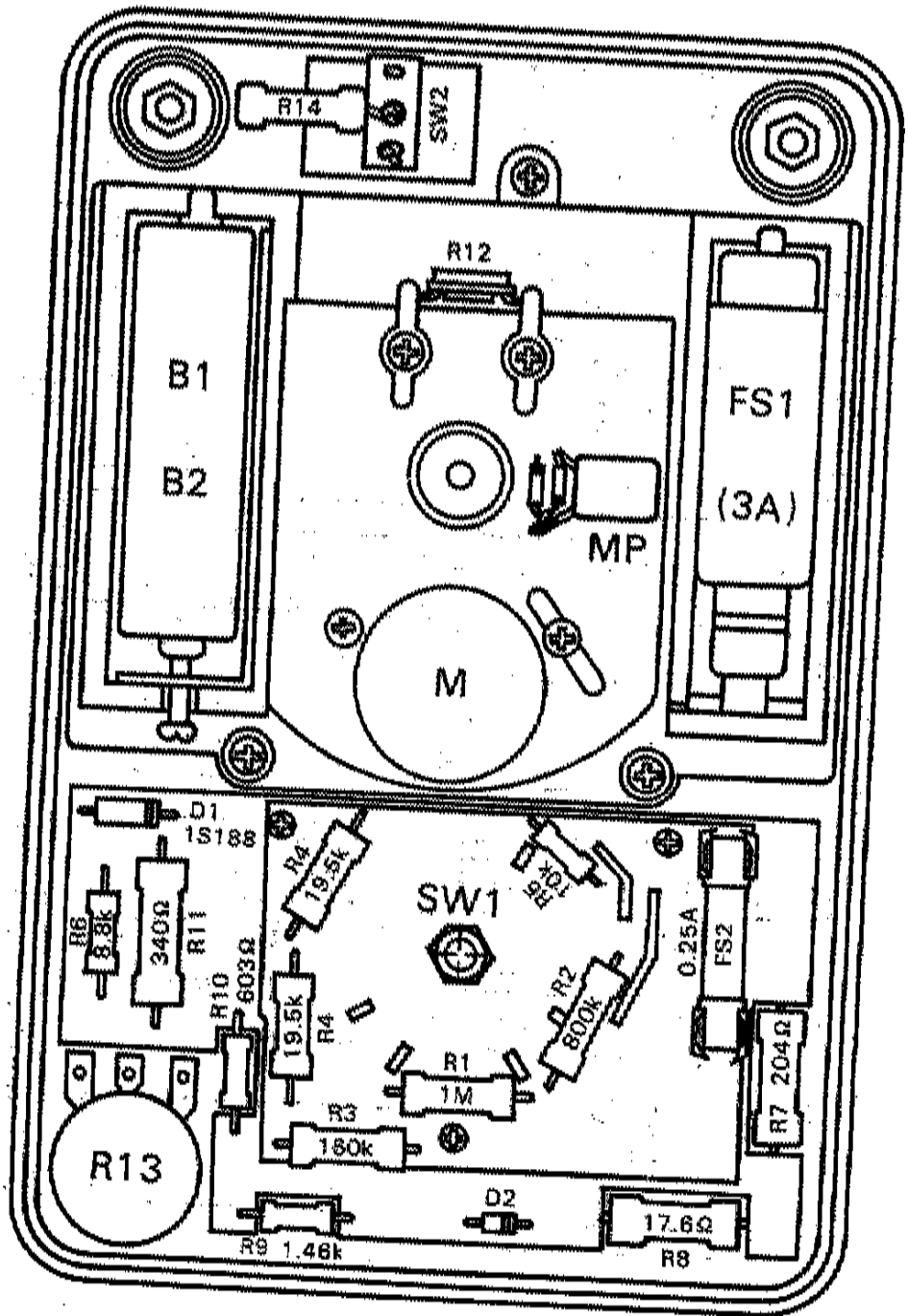

MAIN PARTS LIST

Symbol	Qty	Part name	Remarks
B	2	Dry battery	SUM-3 (1.5V)
FS1	1	Cartridge current-limiting fuse	Rated current 3A
FS2	1	Glass-tube fuse	Rated current 0.25A
M	1	Moving coil-type meter	78.5 μ A \odot 820 Ω
MP	1	Meter overload protection device	1S990A \times 2 0.047 μ F \times 1
R 1	1	Carbonate coated resistor 1M Ω	1/2 W type
R 2	1	" 800k Ω	"
R 3	1	" 160k Ω	"
R 4	2	Oxidized metal-coated resistor 19.5k Ω	1 W type
R 5	1	" 10 k Ω	1/2 W type
R 6	1	" 8.8k Ω	"
R 7	1	" 204 Ω	1 W type
R 8	1	" 17.6 Ω	"
R 9	1	" 1.46k Ω	1/2 W type
R10	1	" 603 Ω	"
R11	1	Carbonate-coated resistor 340 Ω	"
R12	1	Semifixed resistor 1k Ω	
R13	1	Variable resistor 860 Ω	Parallel combination with (R15)
R14	1	Carbonate-coated resistor 80k Ω	1/2 W type
SW1	1	Rotary switch	11 contacts
SW2	1	Pushbutton switch	
D1	1	Germanium diode 1S188	
D2	1	Silicon diode 1N4448	

91-3 ①